

CIRJE-F-222

**Does Natural Selection Mechanism  
Still Work in Severe Recessions?  
Examination of the Japanese Economy in the 1990s**

Kiyohiko G. Nishimura  
The University of Tokyo

Takanobu Nakajima  
Keio University

Kozo Kiyota  
Yokohama National University

May 2003

CIRJE Discussion Papers can be downloaded without charge from:

<http://www.e.u-tokyo.ac.jp/cirje/research/03research02dp.html>

Discussion Papers are a series of manuscripts in their draft form. They are not intended for circulation or distribution except as indicated by the author. For that reason Discussion Papers may not be reproduced or distributed without the written consent of the author.

# Does Natural Selection Mechanism Still Work in Severe Recessions?

– Examination of the Japanese Economy in the 1990s –\*

Kiyohiko G. Nishimura<sup>†</sup>    Takanobu Nakajima<sup>‡</sup>    Kozo Kiyota<sup>§</sup>

May 10, 2003 Version

## Abstract

This paper investigates whether or not the natural selection mechanism (NSM) of economic Darwinism works in severe recessions. Although standard firm models imply the importance of NSM in an economy by showing firm's rational behavior on entry, surviving, and exit leads to macro-level TFP growth, there is almost no evidence to demonstrate NSM works even in severe recessions and depressions. Based on micro data of *the Basic Survey of Japanese Business Structure and Activities (BSJBSA)* by Ministry of Economy, Trade and Industry, we construct a comprehensive firm-level panel dataset for Japan from 1994 to 1998, especially designed for the analysis of a firm's entry, survival, and exit and its relationship with TFP. Empirical results show that efficient firms in terms of TFP quit while inefficient ones survived in the banking-crisis period of 1996-1997. Besides, this phenomenon is mainly observed for new entrants and contributes substantially to a fall in macro TFP after 1996. These facts strongly suggest malfunctioning of NSM in severe recessions.

Keywords: TFP, entry and exit, enterprise census

JEL Classification : D21 (Firm Behavior); D24 (Production; Capital and Total Factor Productivity; Capacity); O47 (Measurement of Economic Growth; Aggregate Productivity); L11 (Production, Pricing and Market Structure; Size Distribution of Firms)

---

\*This paper is a part of our joint research with Flora Bellone, Patrick Musso, and Michel Quéré of Institut de Droit et d'Economie de la Firme et de l'Industrie. We are grateful to Japan Society for the Promotion of Science for financial support. The order of the authors is intentionally reverse-alphabetic.

<sup>†</sup>University of Tokyo

<sup>‡</sup>Keio University

<sup>§</sup>Yokohama National University and Research Institute of Economy, Trade and Industry

# 1 Introduction

Economic Darwinism explains the survival of the fittest firms in relation to the change in the business environment. According to the *laissez-faire* principle, the competitive market guarantees that the natural selection mechanism (NSM) of Darwinism leads to efficient resource allocation, because firms with low profitability are forced to quit and productive ones can survive in the market. As Galor and Moav (2002) explain, the struggle to survive can even trigger revolutions which break blockades and open the way to long term economic growth.

The microeconomic foundation of NSM has been established by the development of sophisticated firm models since Jovanovic (1982). The standard model depicts a firm's decision for entry, surviving, and exiting as a result of maximization of the expected discounted future net cash flows. Olley and Pakes (1996), demonstrated that firms' private decisions in the U.S. telecommunications industry eventually contributed to productivity progress for the industry as a whole.

Several cases of empirical evidence of a firm's entry/exit have suggested the fulfillment of NSM both in developing and advanced economies. It is, however, still not certain whether NSM really works well in severe recessions, because we have rarely experienced a serious economic downturn such as the Great Depression early in the twentieth century, where the market mechanisms might fail to function.

To answer the question of whether NSM really works well in a severe recession, the Japanese economy in the 1990s appears to be a prime example for analysis. The plight of the recent Japanese economy has stirred heated discussion on its causes and remedies. As recession showed its stubbornness despite massive fiscal and monetary stimulation, economists turned their attention toward the supply side of the Japanese economy, especially a large decline in Total Factor Productivity (TFP).<sup>1</sup> Since malfunction of the NSM on a firm's entry, surviving, and exit could explain the decline in macro level TFP, it might be meaningful to investigate how

---

<sup>1</sup>Carefully purging out other factors, Fukao, Inui, Kawai and Miyagawa (2002) found that the rate of Japan's macro TFP growth in 1990s was only 40% of that in 1980s. Nakajima, Kasuya, Saida and Tanemura (2002), based on a dual approach of TFP, revealed that productivity slowdown had already started before the burst of the bubble economy. Nishimura and Shirai (2003) observed serious retardation in technical progress of the Japanese service (includes wholesale & retail trade, transport, and telecommunications) sectors in 1990s. Hayashi and Prescott (2002) utilized a dynamic macro model to show the simulated business cycle caused by productivity slowdown follows the actual GDP fluctuations in Japan.

NSM has functioned in this severe recession period of the Japanese economy.<sup>2</sup>

A dataset at the firm-level for a panel of companies is essential to accomplish this investigation. Most countries unfortunately conduct comprehensive surveys only of establishments in manufacturing, such as the census of manufactures.<sup>3</sup> In contrast, the Ministry of Economy, Trade and Industry of Japan launched *The Basic Survey of Japanese Business Structure and Activities (BSJBSA)*, which covers all commercial firms with 50 employees or more and capitalization of over 30 million yen, who are at least partly engaged in mining, manufacturing, wholesale & retail sales, and restaurant activities. Thus, this data set gives us a unique opportunity to examine whether NSM works in severe recessions in a wide range of industries in a developed economy.

The results are striking. In Japan, efficient firms in terms of TFP went out of business while inefficient ones have survived since 1996. NSM, which is supposedly inherent in a market economy, showed malfunctions. Besides, this phenomenon was mainly observed with new entrants and can explain a considerable part of the fall in macro TFP after 1996. The year 1996 is key to the interpretation of the results, because the vulnerability of the Japanese financial market started to become obvious in 1996 and 1997. Our results might be consistent with the fact that Japanese banks, suffering from non-performing loan problems after the burst of the bubble, finally fell into functional disorder early in 1997.

The remainder of the paper is organized as follows. The next section presents a brief survey of preceding entry/exit studies on both theoretical and empirical sides. Section 3 explores a firm's entry/exit behavior patterns. In Section 4 we show basic TFP calculation results and analyze the relationship between a firm's entry/exit and the industry level TFP. The final section concludes the paper. Detailed descriptions of data sources and calculation methodology of TFP

---

<sup>2</sup>Several empirical works go further than estimating macro- or industry level TFP and investigate the effects of sectoral and regional adjustment on TFP growth. Kuroda and Nomura (1999) and Fukao et al. (2002) calculated a resource reallocation effect among industries on macro TFP and showed its large slowdown in the 1990s. Higuchi, Nakajima, Nakahigashi and Hino (2003) pointed out that the rigidity of an industrial structure in prefectures prevented macro TFP progress in Japan. Bae (2002) decomposed the macro TFP growth of Japan from 1960 to 1999 into a technical progress factor and an efficiency improvement factor and derived a result showing that the latter one has rarely been found. The results of these studies suggest a problem in the adjustment process in Japan.

<sup>3</sup>In the U.S., for instance, because there is no survey of the "real" firm level, firm-level data is constructed by summing up inputs and outputs of establishments that belong to the same firm. This type of firm-level data can be called quasi firm-level data, because it could cause a lack of important information about firms' sales activities, R&D, and personnel management.

are provided in Appendix A and B respectively.

## **2 Theoretical background and empirical experiences**

Entry and exit behavior is one of several choices a firm must make. Standard models of a firm's turnover under a competitive market situation, as depicted in Jovanovic (1982), Hopenhayn (1993), and Ericson and Pakes (1995), suggest that a firm enters (leaves) when entry (exit) is expected to contribute to the projected discounted future net cash flows. Calibration studies have played an essential role in support of this theory. Jovanovic and MacDonald (1994) applied an industry dynamics model to the U.S. automobile tire industry and showed that the model tracked actual movement of the number of firms very well. Pakes and Ericson (1998), using firm-level micro data of manufacturing and retail industries, showed the appropriateness of firm level dynamics models. Campbell (1998) focused on the relationship between business fluctuations caused by productivity shocks and a firm's entry/exit patterns, and showed calibrated numbers relative to the model "mimicking" the real U.S. economy.

Empirical analysis based on firm models is necessary for investigating whether NSM is working properly. The complexity of a rich theoretical model, however, makes it difficult to accomplish a direct statistical test of structural equations. Thus, empirical studies try to examine the feasibility of a firm model by testing the consistency between the model's implication and reality with entry/exit behavior. The model of Hopenhayn (1993), for instance, suggests that exiting firms have lower productivity than surviving firms and productivity distribution will be stochastically increasing in the age of the cohort. If a panel dataset that depicts firms' entry, surviving, and exit behavior is available, we can calculate productivity measures and test whether they really conform to the theory.

There are at least three necessary conditions that need to be met to make an empirical test on this issue truly useful. Firstly, datasets should be constructed completely at the firm level. A firm's entry and exit points are crucially important managerial decisions made by a firm itself. Besides, we must take account of increases of relative significance in non-production activities such as sales, R&D, and personnel affairs in manufacturing firms.<sup>4</sup> You must look at all of the

---

<sup>4</sup>According to Nakajima, Maeta and Kiyota (2000), a cost share of a non-production activities for major 54 electric machinery manufacturing firms was 35% on average in 1996. It is approximately 5 % point increase from 1985.

individual aspects of the firm when trying to reflect the firm as a whole. Only summing up the various elements of a firm does not sufficiently represent the firm for this study. Secondly, service sectors should also be included. The growing significance of non-manufacturing sectors is a general trend observed in most advanced economies. Finally, productivity should be measured in a general form. Labor productivity has the greatest popularity because of its easy calculation and interpretation, but that could be a biased indicator when a resource substitution effect exists. TFP, which is defined as the ratio of output to all input (or input index), has superiority over labor productivity because of its generality.

Viewing preceding empirical studies on a firm's entry, surviving, and exit issues, there are almost none to satisfy all of the above three conditions.<sup>5</sup> The critical lack of firm level surveys is inherent to all of the studies.<sup>6</sup> Baily, Hulten and Campbell (1992) and Haltiwanger (1997) utilized the Longitudinal Research Database and found plant-level entry/exit patterns had significant effects on the overall TFP growth of the U.S. manufacturing industry. Griliches and Regev (1995), focusing on the Israeli manufacturing industry (including mining), found the effects of firm turnover on industry-level labor productivity were quite small. Olley and Pakes (1996) utilized a firm dynamics model and confirmed that since the market liberalization in the 1980 of the telecommunications industry a plant's opening & shutdown dynamics made considerable contributions to the TFP progress in this industry. Aw, Chen and Roberts (2001), using the Taiwanese Census of Manufactures, showed that a firm's turnover made a considerable contribution to industry level TFP growth in Taiwan. Hahn (2000), based on establishment-level panel data for Korean manufacturing sector, derived the same conclusion as Aw et al. (2001).<sup>7</sup>

This paper is the first empirical analysis on this issue completely on a firm level, extending

---

<sup>5</sup>The only one example we are acquainted with is Bellone, Musso and Quéré (2003) targeting French manufacturing industry based on purely firm level panel data. They showed positive contribution of firm's turnover to industry level TFP growth.

<sup>6</sup>Dunne, Roberts and Samuelson (1988) compiled a panel dataset for the U.S. manufacturing industries by gathering the data of establishments within the same firm. For the Canadian manufacturing sector, Baldwin and Gorecki (1991) constructed a database with corresponding establishment information and identified various ways of entry and exit: plant birth, acquisition, or plant switch for entry and plant closing, divestiture, or plant switch for exit through the detailed cohort analysis. These two datasets are on a quasi-firm level, that is, aggregation of establishments.

<sup>7</sup>There are some empirical studies focusing on developing countries. Liu (1993) and Liu and Tybout (1996) measured plant level TFP and made a comparison between entry, surviving, and exiting plants for the Chilean and Colombian economies. The same analysis for Morocco was done by Tybout (1992). All of them concluded that a firm's turnover has a significant effect on macro level productivity growth.

the industry coverage to wholesale & retail trade and others, and based on TFP as an efficiency criterion. Furthermore, we focus only on “active firms” in *BSJBSA* to remove an upward bias of entry and exit caused by “dormant firms”.<sup>8</sup> One common result among the preceding empirical works was that there were no negative contributions of a firm’s turnover to macro TFP growth, which is strong evidence to support the effectiveness of NSM. This paper will answer the question whether the same result is obtained in the case of Japan during a serious recession.

## 3 Data

### 3.1 Data source

The main data source for the overall analysis in this paper is the micro data of *The Basic Survey of Japanese Business Structure and Activities (BSJBSA)* by the Ministry of Economy, Trade and Industry from 1994 to 1998. *BSJBSA* covers all the enterprises with 50 employees or more and greater than a 30 million yen capitalization and engaged in mining, manufacturing, wholesale & retail, or restaurant activities.<sup>9</sup> The Survey also covers firms in agriculture, construction, and various service industries, so long as they also engage at least partly in one of mining, manufacturing, wholesale and retail trade, or restaurant activities.<sup>10</sup> The first and second investigation years are 1991 and 1994 respectively. Only since 1994 has *BSJBSA* data been available for every year. There are four special features in *BSJBSA*.

Firstly, it is a survey of firms. Although rich micro data sources are now available in many countries like the U.S. and Canada, most of them are not based on surveys of firms but of establishments. Certainly establishment data sources are useful for the estimation of production or cost functions from the viewpoint of production technologies. A resource allocation within a firm, however, is determined as a result of managerial decisions. Information about establishments only, such as R&D, M&A, and re-organization, is hardly enough to handle the issues related to managerial strategies of a firm as a whole. In this sense *BSJBSA* provides quite

---

<sup>8</sup>Dunne et al. (1988) excluded the smallest firms from the sample for the same purpose.

<sup>9</sup>See Table 1 for industries that *BSJBSA* covers. The industry classification in the table is based on the System of National Accounts definition.

<sup>10</sup>The organization of Japanese ministries is vertically divided according to the industries of which they should take charge. METI is mainly in charge of manufacturing, electricity, and wholesale & retail trade industries and responsible for gathering their statistics.

Table 1: SNA industry classifications

1	agriculture	13	transportation machinery
2	mining	14	precision machinery
3	foods	15	miscellaneous machinery
4	textile	16	construction
5	pulp & paper	17	electricity, gas & water
6	chemical	18	wholesale
7	petroleum & coal	19	retail
8	stone & clay	20	finance
9	primary metal	21	real estate
10	metal products	22	transportation & communications
11	general machinery	23	service
12	electric machinery		

valuable information to accomplish empirical studies on firm theory.

Secondly, code numbers are attached to all the samples for the identification in *BSJBSA*. Since the code is specific to each firm, we can easily trace it in time series and make a panel data set.

Thirdly, the data source covers a wide range of firm size. Although the utilization of the financial statements is another option to capture a firm's behavior, their availability is limited only to a company whose stock is listed on the stock exchange. *BSJBSA* does not have such a limitation; it is limited only in that it surveys firms with 50 employees or more and a capitalization in excess of 30 million yen.<sup>11</sup>

Finally, *BSJBSA* basically covers only "active firms" in the sense that they are truly engaged in regular business activities, because it imposes a lower limit on the firm size of 50 employees or more and 30 million yen in capital. Inclusion of "dormant firms," which exist just for purposes other than regular business, would lead to seriously biased results on a firm's entry and exit.

<sup>11</sup>However, a serious weakness exists in *BSJBSA* related to the analysis in this paper and that is a lack of information concerning a firm's duration. Suppose firms A and B were merged. There are three possibilities: (1) firm B was merged into A, (2) firm A was merged into B, and (3) they were merged to form a new firm, C. *BSJBSA* provides no information to identify which one actually occurred. It is certainly worth distinguishing the organizational expansion by self-reproduction from that by M&A. In case of (3) firm C should be obviously differentiated from a purely new firm.



## 3.2 Sample selection

*BSJBSA* has some samples with abnormally large or small values in answers to its questionnaires. However, it is difficult to identify which one is a “real” error, because it could be a true value containing worthy information. In this paper we exclude samples that have logically inconsistent values from the data set. A sample is regarded inconsistent if it fits one of the following three cases: (1) at least one of the values of regular workers, investment, capital, debt, identification code, and industry code is missing, (2) at least one of the values of firm age (the year of establishment minus the year of investigation), labor compensation, tangible fixed asset, the number of main offices, and gross value added is missing or negative, and (3) the number of regular workers (including part-time workers) is less than that of part-time workers.

## 3.3 Definitions of entry and exit

In *BSJBSA*, entry and exit are defined as appearance in and disappearance from *BSJBSA* respectively. Entry and exit under this definition do not necessarily correspond to origin and termination, respectively, because, as is mentioned above, samples in *BSJBSA* are censored. Also, we have considerable numbers of re-entry firms that disappear once and re-appear. *BSJBSA* provides no information to identify types of a firm’s entry/exit and re-entry behavior.<sup>12</sup>

To solve the complexity, we present our own definitions of entry, exit, and surviving firms in our data set as follows.

1. Appearance in *BSJBSA* with a new identification code is defined as entry.
2. Reappearance in *BSJBSA* with the same identification code as before is also defined as entry.<sup>13</sup>
3. Either temporary or permanent disappearance from *BSJBSA* is defined as exit.
4. Continuing firms are defined as those which stay in *BSJBSA* for at least two consecutive years.

---

<sup>12</sup>More detailed explanations about this issue are provided in Appendix A.

<sup>13</sup>One might regard this procedure too extreme. We have examined robustness of our results with respect to this procedure and found qualitatively the same result was obtained when we adopted other procedures. See Appendix A.

The panel data set constructed based on the definitions above is definitely unbalanced. Hereafter, we call this data set the N2K (Nishimura-Nakajima-Kiyota) panel, which is utilized for the empirical studies in the following sections.

## 4 Entry/exit behavior of Japanese firms

Previous studies about the entry and exit of Japanese firms have pointed out that there are relatively few in the post World War II period, compared with pre-War periods and other countries. For instance, Nishimura and Kawamoto (2003), utilizing *Company Statistics* (Ministry of Commerce and Industry) and *Establishment and Enterprise Census* (Ministry of Management and Coordination), showed the exit rate of the Japanese firms was less than 1% after 1987 as compared with 6-9% at the pre-war period. (See Table 2) This evidence seems to strongly support the common conviction that firms' entries and exits are relatively rare in Japan. This subsection presents observations like Nishimura and Kawamoto based on *Company Statistics* and *Establishment and Enterprise Census* that could underestimate firms' "economically meaningful" entry and exit behavior.

In popular terminology, "exit" means a complete closure of business. However, according to this definition, "dormant" firms with no significant business but which are not closed are classified as continuing firms. It is well known in Japan that there are a sizable number of "dormant firms" existing simply for tax-shelter and/or other purposes, though it is very difficult to determine the number of such dormant firms.

In economic analysis of productivity, we are concerned not with dormant firms, but "active" firms. In this respect, entry and exit numbers presented in the previous studies, based on *Company Statistics* and the like, are misleading since they contain many dormant firms. In contrast, in *BSJBSA*, where firms with 50 employees or more and a capitalization in excess of 30 million yen are investigated, these firms are likely to be "active." Thus, the entry/exit behavior observed in the N2K panel illustrates the dynamics of "active firms" as properly defined.

Table 3 depicts how firms originated in a certain year have survived since then.<sup>14</sup> While the

---

<sup>14</sup>Since there is a two-year blank in investigation between the first investigation (in 1991) and the second investigation (in 1994), a sample identified as a closing firm in 1994 in *BSJBSA* would have already disappeared in 1992 or 1993. We calculated survival rates in 1994 for "before 1991 entry" cohort on an annual basis by dividing original hazard rates by three.

Table 2: Creation and destruction of Japanese enterprises

Source: Nishimura and Kawamoto (2003)

**Pre-World War II Era**

year	All Industries	By Industry					
		Agriculture	Fisheries	Mining	Manufacturing	Commerce	Transport
Rate of Net Increase							
1924-28	5.38%	2.70%	2.03%	1.17%	3.51%	6.49%	9.04%
1934-40	0.40%	-6.55%	-0.43%	16.62%	3.09%	-1.88%	2.75%
Rate of Creation (Rate of New Enterprises)							
1924-28	10.93%	6.30%	8.29%	5.34%	9.55%	11.98%	13.22%
1936-40	9.25%	5.09%	7.79%	19.93%	11.32%	7.76%	9.88%
Rate of Destruction (Estimated)							
1924-28	6.65%	3.97%	6.70%	4.35%	6.80%	6.83%	5.69%
1936-40	8.97%	9.43%	8.10%	5.77%	9.09%	9.07%	7.81%

Source: Shoko Sho (Ministry of Commerce and Industry), *Kaisha-Tokei (Company Statistics)*, 1929 (22-25, 258-261), 1930 (22-25, 260-263), and 1945 (22-25, 364-365).

Notes: The rate of net increase is the change in the number of existing companies at the end of the fiscal year. The rate of creation is the ratio of newly-established companies to the existing companies. The rate of destruction is estimated from the rate of creation and the rate of net increase. The rates are the average of annual rates.

**Post-World War II Era**

year	All industries	By Industry						
		Construction	Manufacturing	Wholesale Trade	Retail Trade	Eating and Drinking Places	Services	Miscellaneous
Rate of Net Increase								
1981-86	2.31%	3.17%	1.18%	1.97%	1.49%	1.23%	5.31%	3.08%
1987-91	3.25%	5.26%	2.09%	1.66%	1.30%	4.53%	6.04%	4.72%
1992-96	1.41%	3.92%	-0.30%	-1.20%	1.80%	1.21%	2.87%	1.42%
Rate of Creation (Estimated)								
1981-86	3.52%	5.46%	2.25%	3.56%	2.25%	1.90%	6.10%	4.11%
1987-91	3.76%	5.98%	2.53%	2.48%	1.62%	4.80%	6.39%	5.28%
1992-96	2.12%	4.90%	0.44%	-0.08%	2.16%	1.55%	3.40%	2.19%
Rate of Destruction (Bankruptcy Rate)								
1981-86	1.33%	2.58%	1.12%	1.72%	0.82%	0.70%	0.97%	1.16%
1987-91	0.57%	0.88%	0.48%	0.88%	0.33%	0.33%	0.44%	0.68%
1992-96	0.75%	1.14%	0.73%	1.07%	0.38%	0.35%	0.59%	0.82%

Source: For, net increase and creation, Somu Cho (Management and Coordination Agency), *Jigyosho Kigyo Tokei (Establishment and Enterprise Census)*, 1981 (Vol. 3, Table 3), 1986 (Vol. 3, Part 1, Table 4), 1991 (Vol. 3, Table 4), 1996 (Vol. 3-1, Table 3). For destruction, Chusho Kigyou Jigyoudan (Japan Small and Medium Enterprise Corporation), *Kigyou Tousan Chousa Nenpou (Annual Report of Bankruptcy companies)*, 1990 (Table 14-1) and 1997 (Table 14-1).

Notes: The rate of net increase is change in the number of existing companies at the each survey date. The survey of existing companies was undertaken as of July 1 in 1981, 1986, and 1991 and October 1 in 1996. The number of destruction is calculated at the end of fiscal year. Destruction means disposition by suspension of bank credit, [legal] bankruptcy, an application for composition, a ruling of reorganization and rehabilitation or a ruling of liquidation. For destruction of enterprises with the total amount of the debt under ten million yen, 215 major cities are surveyed, while the whole country is surveyed for destruction with the total amount of the debt no less than ten million yen. Thus, the rate of destruction is slightly underestimated since destruction in small cities may not be properly counted. The rate of creation is estimated from the rate of destruction and the rate of net increase. The rates are the average of annual rates.

Table 3: Entry and exit patterns in the N2K panel

		Cohorts					
		Entry					
		before 1991	in 1994	in 1995	in 1996	in 1997	in 1998
<b>Number of firms</b>							
1991		23,914					
1994		19,923	4,870				
1995		18,227	3,876	3,844			
1996		16,970	3,361	3,054	2,433		
1997		15,689	2,928	2,553	1,802	2,809	
1998		14,610	2,607	2,233	1,507	2,178	2,670
<b>Entry and Exit rate (%)</b>							
	Entry		20.4	15.5	9.4	10.9	10.4
	Exit		16.7	10.8	9.9	11.0	10.3
<b>Unconditional survival rate (%)</b>							
1991		100.0					
1994		94.1	100.0				
1995		76.2	79.6	100.0			
1996		71.0	69.0	79.4	100.0		
1997		65.6	60.1	66.4	74.1	100.0	
1998		61.1	53.5	58.1	61.9	77.5	100.0
<b>Conditional survival rate (%)</b>							
1991		100.0					
1994		83.3	100.0				
1995		91.5	79.6	100.0			
1996		93.1	86.7	79.4	100.0		
1997		92.5	87.1	83.6	74.1	100.0	
1998		93.1	89.0	87.5	83.6	77.5	100.0

- Notes: 1) An unconditional survival rate stands for a ratio of the number of surviving firms to that in the original entry year.  
2) A conditional survival rate stands for a ratio of the number of surviving firms to that in the previous year.  
3) Values in 1994 are annual means. Values in 1991 show the number of firms born exactly in 1991 and before then.

Source: N2K Panel data

“unconditional” rate is a ratio of the number of surviving firms to the number of firms in their entry year, “conditional” means a comparison with the previous year.

From the table, we obtain three outstanding findings. Firstly, survival rates just after entry are quite low. More than 20% of new entrants exit from the pool of active firms within the next year, and 30% exit within two years later. Secondly, entry/exit rates are very high unlike Nishimura and Kawamoto (2003) findings. This result shows that Japanese firms of certain employment levels and capital sizes have been more frequently taking actions of entry and exit than observed in the previous studies. This result suggests that low entry/exit rates of previous studies, including dormant firms, may be misleading with respect to entry and exit of economically “active” firms.<sup>15</sup> Finally, survival probabilities rise as time passes. For a firm to live for a long time, it has to overcome difficulties in its infancy.

It should be emphasized here that the results in Table 3 are comparable with those for the U.S. and Canada with some reservations.<sup>16</sup> The entry rates of 10 to 20% in Table 3 are much higher than the Canadian case (2 to 7%), but less than the U.S. case (30 to 50%). The same relationship holds for the exit rates of the three countries, although Canada showed 10.1% exit rate in 1981 (Table 2, p.308), which is very close to that of Japan. On the contrary, surviving rates are primarily the same for the three economies. The five-year- (four-year in case of Japan) surviving rate of the entry cohort is 40 to 60% for the U.S., 40% for Canada (1970 cohort), and 47% for Japan (1994 cohort).

## 5 Entry/exit and TFP

Resemblance and difference in entry/exit patterns alone are not enough to evaluate NSM of the Japanese economy. In this section we examine whether firms with relatively higher performance survive and those with lower performance exit. Among various measures of firm performance, total factor productivity (TFP) is chosen in this paper. Although labor productivity has great

---

<sup>15</sup>A careful reader might point out that the N2K panel overestimates entry/exit frequencies because it treats re-entry firms as new entrants. To confirm whether this N2K data processing is influential or not, refer to Table A1 in Appendix based on the original *BSJBSA* data set. According to the row 52 to 58, there exist 382 firms that appear in 1994, disappear in 1995, and reappear after 1996. Even if these firms are taken into account in Table 3, more than 10% of firms originating in 1994 closed within one year.

<sup>16</sup>Dunne et al. (1988) covers all plants and their subsidiary firms except the smallest firms (e.g. one employee firms) in the U.S. manufacturing industry. Baldwin and Gorecki (1991) also constructed dataset on manufacturing plants and firms in Canada. Covering periods are 1963 to 1982 for the U.S., 1970 to 82 for Canada.

popularity because of its easy handling, TFP is preferable from the viewpoint of comprehensiveness. In particular, we analyze the issue in two respects. Firstly, we examine whether less productive firms quit from the market. Secondly, we investigate how firms' turnover affects the aggregate or macro TFP growth.

## 5.1 TFP measurement results

First we show the basic results of macro (industry) level TFP in Table 4.<sup>17</sup> The numbers are measured in terms of logarithms. The macro level TFP in the table is calculated from firm level TFP as follows.

$$\ln \widetilde{\text{TFP}}_t = \sum_i v_t^i \ln \text{TFP}_t^i, \quad (1)$$

where  $v_t^i$  stands for value added share for firm  $i$  at term  $t$ . According to Olley and Pakes (1996), the equation (1) can be rewritten as

$$\begin{aligned} \ln \widetilde{\text{TFP}}_t &= \ln \bar{\text{TFP}}_t + \sum_i \Delta v_t^i \Delta \ln \text{TFP}_t^i, & (2) \\ \Delta v_t^i &= v_t^i - \bar{v}_t \\ \Delta \ln \text{TFP}_t^i &= \ln \text{TFP}_t^i - \ln \text{TFP}_t, \end{aligned}$$

where  $\bar{v}_t$  is an arithmetic mean of firm's value added share at time  $t$ . The first term is non-weighted mean of firms' TFP and the second term is covariance of firms' TFP and value-added share. The value of the second term will be positive (negative) if there is a positive (negative) correlation between a firm size and TFP.

Table 4 shows the results of macro (industry) level TFP and its decomposition based on (2) for ten major industries.<sup>18</sup> The value of a covariance term is positive for all industries throughout the observation period, which implies that the firm-level economies of scale are widely observed in major industries that *BSJBSA* covers. It has been repeatedly confirmed that there exist economies of scale at establishment level in the Japanese manufacturing industry.<sup>19</sup>

---

<sup>17</sup>The calculation method of TFP including input/output definitions and data sources is described in Appendix B.

<sup>18</sup>We note that value added share  $v_t^i$  used at the calculation in Table 4 is the ratio of firm  $i$ 's nominal value added to total nominal value added of the "industry" that firm  $i$  belongs to.

<sup>19</sup>See, for example, Nakajima, Nakamura and Yoshioka (1998).

Table 4: Industry level TFP and its decomposition

	Industry level lnTFP	Non-weighted mean lnTFP	Covariance		Industry level lnTFP	Non-weighted mean lnTFP	Covariance
<b>Food products and beverages</b>				<b>Transportation machinery</b>			
1994	0.639	-0.176	0.815	1994	0.097	-0.072	0.169
1995	0.721	-0.136	0.857	1995	0.236	-0.049	0.285
1996	0.724	-0.134	0.858	1996	0.281	-0.087	0.368
1997	0.753	-0.140	0.892	1997	0.219	-0.123	0.343
1998	0.756	-0.131	0.887	1998	0.101	-0.234	0.335
<b>Textiles</b>				<b>Precision machinery</b>			
1994	0.037	-0.237	0.275	1994	-0.123	-0.154	0.031
1995	0.167	-0.169	0.336	1995	-0.035	-0.086	0.051
1996	0.079	-0.196	0.275	1996	0.035	-0.073	0.108
1997	0.120	-0.215	0.335	1997	0.110	-0.106	0.215
1998	0.049	-0.277	0.326	1998	0.211	-0.041	0.252
<b>Chemicals</b>				<b>Wholesale trade</b>			
1994	0.552	0.207	0.345	1994	0.542	0.025	0.517
1995	0.674	0.229	0.445	1995	0.519	0.057	0.462
1996	0.808	0.306	0.501	1996	0.554	0.084	0.470
1997	0.884	0.351	0.533	1997	0.544	0.082	0.462
1998	0.831	0.330	0.501	1998	0.655	0.166	0.490
<b>General machinery</b>				<b>Retail trade</b>			
1994	0.195	-0.116	0.311	1994	-0.152	-0.273	0.121
1995	0.385	-0.018	0.403	1995	-0.086	-0.245	0.160
1996	0.445	-0.015	0.460	1996	-0.066	-0.236	0.170
1997	0.390	0.005	0.384	1997	-0.091	-0.268	0.177
1998	0.429	-0.065	0.494	1998	-0.073	-0.195	0.122
<b>Electrical machinery</b>				<b>Construction</b>			
1994	0.273	-0.193	0.466	1994	0.179	0.119	0.060
1995	0.391	-0.055	0.445	1995	0.303	0.054	0.250
1996	0.692	0.058	0.634	1996	0.219	0.093	0.126
1997	0.815	0.173	0.642	1997	0.240	0.057	0.183
1998	0.664	0.166	0.498	1998	0.347	0.050	0.296

Source: N2K Panel Data

Table 5: Growth rates of non-weighted means of firm TFP for industries

	1994-95	1995-96	1996-97	1997-98
Agriculture, forestry and fishing	0.370	0.219	-0.102	0.051
Mining	0.097	0.076	0.086	-0.043
Food products and beverages	0.040	0.005	0.006	0.010
Textiles	0.048	-0.034	-0.036	-0.066
Pulp, paper and paper products	0.024	0.010	0.038	-0.034
Chemicals	0.021	0.062	0.046	-0.030
Petroleum and coal products	0.045	0.071	0.024	-0.090
Non-metallic mineral products	0.064	0.010	0.033	-0.095
Iron, Steel and non-ferrous metals	0.034	0.062	0.009	-0.108
Fabricated metal products	0.056	-0.001	-0.020	-0.038
General machinery	0.088	0.012	0.032	-0.061
Electrical machinery	0.134	0.104	0.101	-0.035
Transportation machinery	0.033	-0.040	-0.027	-0.103
Precision machinery	0.072	0.020	-0.024	0.052
Other manufacturing	0.050	0.041	-0.009	-0.044
Construction	-0.074	0.024	-0.021	-0.041
Electricity, gas and water supply	-0.002	-0.047	0.201	-0.042
Wholesale trade	0.030	0.016	-0.006	0.082
Retail trade	0.025	0.013	-0.026	0.073
Finance and insurance	0.385	0.264	0.042	0.049
Real estate	0.205	0.017	-0.041	-0.082
Transport and communications	-0.024	0.008	0.180	0.114
Service activities	0.024	0.067	-0.019	0.030

Source: N2K panel data

At the firm level, on the other hand, it seems ambiguous, because we have few empirical studies on this issue.<sup>20</sup> The result in Table 4 is the first evidence to show large firms' relative efficiency.

Table 5 summarizes annual growth rates of non-weighted means of firm TFP for industries. Until 1996 positive changes had been widely observed. TFP downturn started from 1996 to 1997 and spread over the entire industry in 1998.

## 5.2 Cohort analysis of TFP

### *How does NSM work in the market?*

If economic Darwinism is applicable to the market economy, those organizations, which are efficient in the business environment, will drive others out. In other words, firms with high productivity would survive while those with low productivity would exit. As a matter of fact,

<sup>20</sup>Nakajima, Nakamura, Nakamura and Nakamura (2003) shows economies of scale are not widely observed for enterprises listed on the Tokyo Stock Exchange.



Figure 1: Grouping of firms according to entry-cohort

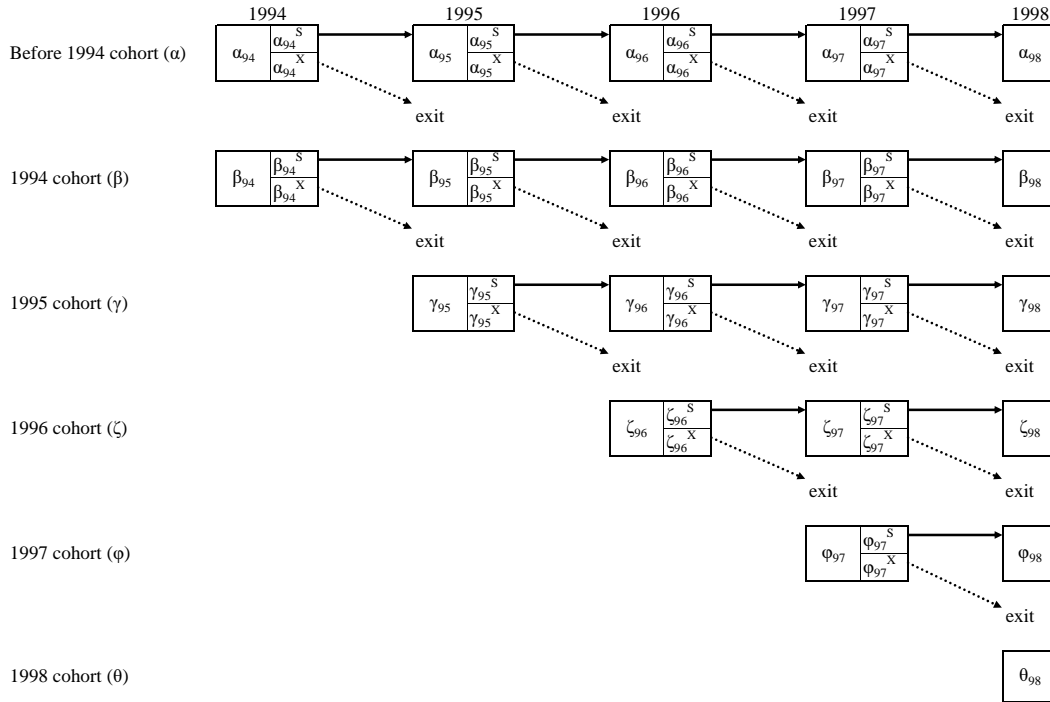

the efficiency of a competitive market economy is based on NSM. In this subsection we examine whether NSM worked in the Japanese market in the 1990s.

Figure 1 illustrates the classification of firms according to the information about when they appear in *BSJBSA* and disappear.<sup>21</sup> Greek letters from  $\alpha$  to  $\theta$  identify the entry years of firms. Subscript numbers point to the years when firms exist in *BSJBSA*. To illustrate,  $\gamma_{96}$  means a group of firms that appeared in 1995 and at least existed in 1996. Superscripts, S and X, indicate “surviving” and “exit” firms in a group of firms in the year of a subscript number. Firms of group  $\beta_{97}^X$ , for example, entered in 1994, at least existed in 1997, and disappeared in 1998.

Table 6 displays (non-weighted) arithmetical means of TFP indices for classified firms in Figure 1. Differences between mean values of surviving and exiting firms are *not* significant at least at the 5% level except  $\alpha_{94}$ . Shaded areas just show that the TFP of exiting firms is

<sup>21</sup>We have referred to Aw et al. (2001) to draw the figure.

Table 6: TFP for entry, surviving, and exit firms

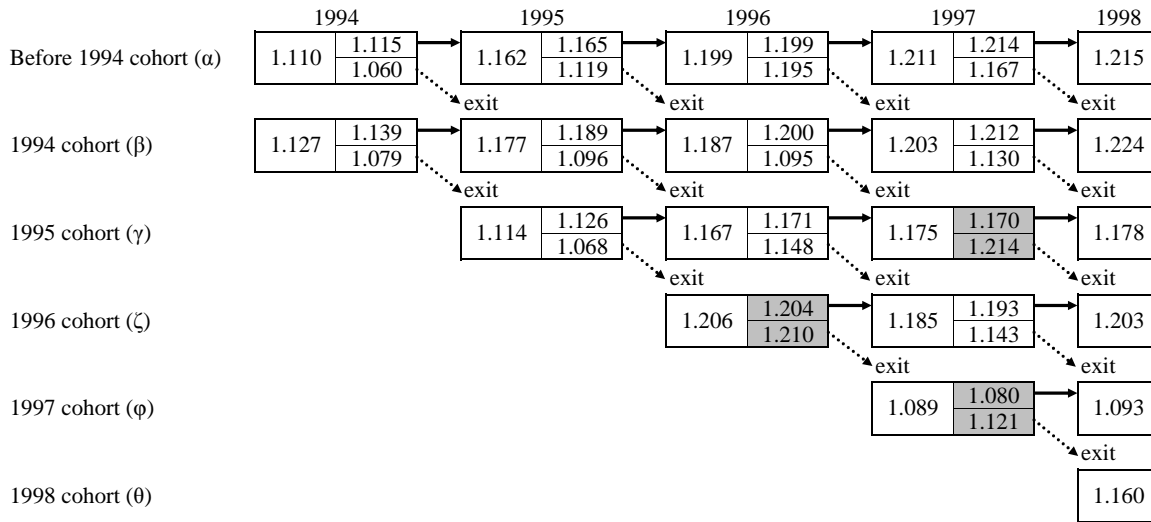

Note: Shaded areas indicate a non-weighted mean of TFP of exiting firms is greater than that of surviving firms.

greater than that of surviving firms. Although significant differences are not observed, we can collect some noteworthy messages from the table. For the cohort of before-1994, 1994, and 1995 entrants, TFP levels of “active firms” have been increasing yearly while less productive firms exit. This is consistent with the implication derived from the model in Olley and Pakes (1996) and the empirical results from Tybout (1992), which show the market mechanism was appropriately working at that time. On the other hand, the TFP cohort of 1996 entrants shows the opposite direction of change to 1997, because more productive infant firms had exited before 1997. For 1997 entrant’s cohort the same tendency is observed. These results may suggest a malfunction of NSM in Japan since 1996.

### *Observation on industry level*

To assess the effectiveness of NSM at industry levels, we should consider an additional channel of entry and exit. It is a switchover from one industry to another. Suppose firm A converts its main product from X to Y. It will be re-classified and treated as an exit firm in X industry and an entry firm in Y. Because firm A is obviously different from a “real” or greenfield entry firm in the Y industry, it is desirable to distinguish firms such as A from others.

We selected three industries: manufacturing, wholesale & retail, and construction and made calculations of non-weighted mean TFP indices for entry, surviving, switching, and exiting firms as shown in Table 7. Shaded areas indicate TFP indices of switching out and exiting firms are higher than those of surviving firms at a 5% significance level. Results in manufacturing industries are in sharp contrast with those in wholesale & retail industries. In manufacturing industries, less productive firms have exited from the pool of active firms, while more productive firms have shifted to other industries (and thus become entry firms with higher productivity). In wholesale and retail trade industries surviving firms have shown lower TFP than exiting firms and more productive firms have shifted from these industries. These findings suggest NSM is effectively working in manufacturing industries, but it is not in wholesale and retail industries. In contrast, few significant differences between surviving, switching, and exiting firms are found in the construction sector.<sup>22</sup>

### 5.3 Effect of entry/exit on industry level TFP

If there is neither entry/exit nor switch-in/out, industry level TFP growth rate in the equation (1) shows a consistent decomposition into the contribution of each firm's TFP growth and that of a change in its value-added share.

$$\begin{aligned} \ln \widetilde{\text{TFP}}_{t+1} - \ln \widetilde{\text{TFP}}_t &= \sum_i v_{t+1}^i \ln \text{TFP}_{t+1}^i - \sum_i v_t^i \ln \text{TFP}_t^i \\ &= \sum_i \left( \frac{v_t^i + v_{t+1}^i}{2} \right) (\ln \text{TFP}_{t+1}^i - \ln \text{TFP}_t^i) \end{aligned} \quad (3)$$

$$+ \sum_i \left( \frac{\ln \text{TFP}_t^i + \ln \text{TFP}_{t+1}^i}{2} \right) (v_{t+1}^i - v_t^i) \quad (4)$$

The second term of the above expression is called “re-allocation effect” because a gain in market share by a productive firm makes a positive contribution to macro level TFP.

The decomposition of (4), however, is not applicable to unbalanced panel data containing firms of entry/exit and switch-in/out. A more general decomposition formula, including the

---

<sup>22</sup>We should be careful to interpret the result of the construction sector, however. As shown before, construction firms in *BSJBSA* are mostly small and medium size enterprises that also engage in manufacturing as their minor activities.

Table 7: Non-weighted mean TFP for entry, switching, and exit firms

	1994	1995	1996	1997
<b>Manufacturing</b>				
Before 1994 cohort ( $\alpha$ )	surviving 1.100 switching 1.173 exit 1.001	surviving 1.169 switching 1.295 exit 1.085	surviving 1.214 switching 1.207 exit 1.202	surviving 1.262 switching 1.364 exit 1.166
1994 cohort ( $\beta$ )	entry 1.052 switching 1.391 exit 0.948	surviving 1.105 switching 1.177 exit 1.100	surviving 1.161 switching 1.222 exit 1.092	surviving 1.205 switching 1.201 exit 1.097
1995 cohort ( $\gamma$ )		entry 1.085 switching 1.218 exit 1.030	surviving 1.144 switching 1.714 exit 1.118	surviving 1.163 switching 1.220 exit 1.130
1996 cohort ( $\zeta$ )			entry 1.175 switching 1.289 exit 1.065	surviving 1.239 switching 1.270 exit 1.129
1997 cohort ( $\phi$ )				entry 1.142 switching 1.126 exit 1.103
<b>Wholesale and retail trade</b>				
Before 1994 cohort ( $\alpha$ )	1.119 1.152 1.124	1.140 1.220 1.166	1.160 1.146 1.161	1.120 1.272 1.176
1994 cohort ( $\beta$ )	1.189 1.035 1.160	1.264 1.277 1.102	1.200 1.320 1.127	1.168 1.196 1.154
1995 cohort ( $\gamma$ )		1.158 1.067 1.111	1.167 1.077 1.142	1.153 1.097 1.241
1996 cohort ( $\zeta$ )			1.242 0.937 1.351	1.126 1.142 1.147
1997 cohort ( $\phi$ )				1.242 1.158 1.286
<b>Construction</b>				
Before 1994 cohort ( $\alpha$ )	1.467 1.416 1.515	1.494 1.008 1.619	1.537 1.569 1.113	1.591 1.064 0.556
1994 cohort ( $\beta$ )	1.586 1.746 1.443	1.491 1.340 1.343	1.566 1.033 1.014	1.677 1.347 1.175
1995 cohort ( $\gamma$ )		1.335 1.000 1.322	1.696 1.059 1.369	1.740 0.954 1.099
1996 cohort ( $\zeta$ )			1.523 1.129 1.176	1.638 0.382 1.449
1997 cohort ( $\phi$ )				0.629 1.380 0.991

Note: Shaded areas indicate TFP indices of switching and exiting firms are higher than those of surviving firms at 5% significant level.

effect of entry and exit firms, is given by Griliches and Regev (1995) as follows.

$$\begin{aligned}
\ln \widetilde{\text{TFP}}_{t+1} - \ln \widetilde{\text{TFP}}_t = & \left( \frac{v_t^X + v_{t+1}^E}{2} \right) (\ln \text{TFP}_{t+1}^E - \ln \text{TFP}_t^X) \\
& + \left( \frac{v_t^I + v_{t+1}^O}{2} \right) (\ln \text{TFP}_{t+1}^I - \ln \text{TFP}_t^O) \\
& + \sum_{i \in C} \left[ \left( \frac{v_t^i + v_{t+1}^i}{2} \right) (\ln \text{TFP}_{t+1}^i - \ln \text{TFP}_t^i) \right] \\
& + \left( \frac{\ln \text{TFP}_{t+1}^E + \ln \text{TFP}_t^X}{2} \right) (v_{t+1}^E - v_t^X) \\
& + \left( \frac{\ln \text{TFP}_{t+1}^I + \ln \text{TFP}_t^O}{2} \right) (v_{t+1}^I - v_t^O) \\
& + \sum_{i \in C} \left[ \left( \frac{\ln \text{TFP}_{t+1}^i + \ln \text{TFP}_t^i}{2} \right) (v_{t+1}^i - v_t^i) \right], \quad (5)
\end{aligned}$$

where the superscripts  $E$ ,  $X$ ,  $I$ , and  $O$  symbolize entry, exit, switch-in, and switch-out firms respectively.<sup>23</sup> The first term stands for the effect of the TFP difference between entry and exit firms that becomes positive (negative) when TFP for entry firms is higher (lower) than exit firms. The same effect in the case of switch-in and out firms is shown in the second term. The third term is the contribution of surviving firms' TFP growth. The fourth, fifth, and sixth terms mean "re-allocation effects" through entry/exit and switch-in/out channels and changes in market shares for surviving firms respectively.

The decomposition results for major industries are shown in Table 8. For most industries especially major manufacturing sectors, continuing firms' performances are quite influential to industry level TFP growth. At this point our results are consistent with the results of preceding studies like Griliches and Regev (1995) and Haltiwanger (1997). The effect of switch-in/out is an indicator to investigate whether relatively productive firms come from or go out to other sectors. Looking at the numbers in the third column, there is no industry with constantly positive or negative effects. The effect of market share reallocation in the fourth column is positive when resources are shifted from less productive to more productive firms. The numbers, however, are mostly negative, especially for chemicals, transportation machinery, precision machinery, and

<sup>23</sup>Productivity levels  $\ln \text{TFP}_{t+1}^E$ ,  $\ln \text{TFP}_t^X$ ,  $\ln \text{TFP}_{t+1}^I$ , and  $\ln \text{TFP}_t^O$  are value added share weighted means of TFP for entry, exit, switch-in, and switch-out firms between  $t$  and  $t + 1$  respectively.

Table 8: Decomposition of macro level TFP growth rate

	TFP growth	Continuing firms	Switch-in vs. switch-out	Market share reallocation	Entry vs. exit
<b>Food products and beverages</b>					
1994-95	-0.036	0.084	0.028	-0.196	0.048
1995-96	-0.067	0.008	0.018	-0.126	0.033
1996-97	0.117	0.050	-0.038	0.138	-0.033
1997-98	0.041	-0.008	-0.026	0.071	0.004
<b>Textiles</b>					
1994-95	0.125	0.102	0.040	-0.016	-0.001
1995-96	-0.085	-0.062	-0.007	0.008	-0.025
1996-97	0.094	-0.003	0.040	0.096	-0.039
1997-98	0.014	-0.020	-0.153	0.197	-0.010
<b>Chemicals</b>					
1994-95	-0.008	0.121	0.019	-0.186	0.037
1995-96	0.209	0.128	-0.007	0.095	-0.007
1996-97	0.056	0.050	0.091	-0.026	-0.058
1997-98	-0.073	-0.069	-0.006	-0.012	0.014
<b>General machinery</b>					
1994-95	0.194	0.197	-0.057	0.022	0.032
1995-96	0.044	0.053	0.008	-0.032	0.015
1996-97	0.057	-0.058	-0.017	0.167	-0.035
1997-98	-0.045	-0.037	0.118	-0.111	-0.015
<b>Electrical machinery</b>					
1994-95	0.072	0.108	0.013	-0.075	0.026
1995-96	0.280	0.295	0.009	-0.013	-0.011
1996-97	0.219	0.094	-0.015	0.157	-0.017
1997-98	-0.148	-0.115	-0.058	0.012	0.013
<b>Transportation machinery</b>					
1994-95	0.118	0.142	-0.002	-0.027	0.004
1995-96	0.079	0.026	-0.001	0.059	-0.005
1996-97	-0.066	-0.053	0.004	-0.011	-0.006
1997-98	-0.133	-0.133	0.003	-0.011	0.008
<b>Precision machinery</b>					
1994-95	0.151	0.021	-0.038	0.120	0.048
1995-96	0.070	0.013	0.051	-0.002	0.008
1996-97	0.043	0.025	0.126	-0.060	-0.048
1997-98	0.039	0.041	-0.042	-0.098	0.138
<b>Wholesale trade</b>					
1994-95	-0.042	-0.026	-0.006	-0.042	0.031
1995-96	0.036	0.028	-0.001	-0.025	0.035
1996-97	-0.012	-0.012	0.015	-0.003	-0.011
1997-98	0.102	0.124	-0.004	-0.014	-0.003
<b>Retail trade</b>					
1994-95	0.003	0.061	0.020	-0.124	0.046
1995-96	0.038	0.019	0.001	0.028	-0.010
1996-97	0.010	-0.007	-0.027	0.080	-0.035
1997-98	0.028	0.024	-0.003	0.014	-0.007
<b>Construction</b>					
1994-95	-0.004	-0.105	0.307	-0.203	-0.002
1995-96	-0.028	-0.133	0.048	0.098	-0.041
1996-97	0.183	-0.060	-0.015	0.346	-0.088
1997-98	0.030	-0.026	0.207	-0.133	-0.019

Source: N2K Panel Data

wholesale trade sectors, which illustrates that resource misallocation among existing firms has been occurring in the Japanese market. Finally, the entry/exit effect has negative values for many cases. Textile and construction industries especially show constantly negative contributions to industry level TFP growth. For other industries, values from 1996 to 97 are negative. This finding, consistent with the results in Table 6 and 7, indicates there were wide occurrences of market malfunction at that time.

As was discussed in Section 2, preceding studies have shown diversified results on entry/exit contribution according to the target economies. In the case of Japan, continuing firms' TFP has been influential to industry level TFP and this is similar to the U.S. manufacturing industry. What should be emphasized here, however, is that a firm's turnover effect was negative and an efficient resource allocation system through a firm's entry/exit channels seems to have been functioning poorly in terms of TFP growth.

## **5.4 Discussion**

Well-functioning financial markets are important in easing firms' entry, survival, and exit behavior. While banks and venture capital help entrepreneurs to get started, declining stock prices and withdrawal of bank loans force firms to leave their competitive market. Among the several avenues for a firm to raise funds, loans from banks still have nearly a 40% share of total funds for commercial firms in Japan, although its relative dominance has been decreasing steadily.<sup>24</sup> Thus, some evidences of market malfunctioning as shown in the previous section can be interpreted in connection with serious non-performing loan problems within the Japanese banking system.

As in Stiglitz and Weiss (1981), credit rationing itself could occur because of asymmetric information between lenders and borrowers even if financial markets are functioning properly. The real problem is whether funds go to productive firms. Cabinet Office (2001) pointed out that serious credit shrinking occurred in 1996 as a result of the unwillingness of banks to loan the available decreasing capital which had been badly damaged by decreasing stock prices since the burst of bubble. Even with low interest rates, investment in small and medium sized firms fell in 1997 and 1998. There is additional suggestive evidence provided in Figure 2-2-6 of

---

<sup>24</sup>See Hoshi and Kashyap (1999) for more details about the structural change in the Japanese financial markets since 1980s.

Cabinet Office (2001) which shows that TFP of sectors with the larger share of banking loans has been lower than the national level of TFP since 1985, and the gap between the two expanded in 1996.<sup>25</sup> This observation coincides exactly with our results.

These findings also have theoretical backgrounds. Kobayashi, Saita and Sekine (2002) presents a model to explain that “forbearance of lending” to unproductive firms would occur as a result of a bank’s rational profit maximization behavior when additional lending leads to fewer losses than withdrawal of loans. They estimated a non-linear loan supply function and showed that increases in a firm’s debt over a certain level induced more loan supply from banks in the last half of 1990s. Fukao, Nishimura, Sui and Tomiyama (2003) model two alternatives that banks face at their profit maximization. One is screening of lending opportunities, and another is improving borrower firms’ performances. They show that screening activity has been more dominant in the Japanese banking system than previously and point out that the economic downturn in the 1990s badly damaged banks. Many banks lost good lending opportunities after the burst of bubble and, in many cases, they have also been unable to raise borrower firms’ profitability. These models indicate the possibility that banks’ “rational” behavior, under certain situations, could make productive firms leave and unproductive firms stay.

## 6 Conclusion

It has been widely accepted that the natural selection mechanism (NSM) of economic Darwinism in competitive markets plays a key role in efficient resource allocation and evolution for long-term economic growth. Recent development of firm models provides theoretical background to the NSM in terms of productivity growth, showing that firms’ rational decisions on entry, surviving, and exit leads to macroeconomic TFP growth.

We have attempted to examine whether NSM works properly in the most stressful circumstances, e.g., severe recessions. Preceding empirical studies on this issue have examined the working of NSM only in normal times and have shown evidence to support proper functioning of NSM with positive contribution of a firm’s turnover to macro level TFP growth. However, the real “test” of NSM is admittedly not normal times but rather times of crisis. We have focused on the 1990s in the Japanese economy as our period of investigation, with special focus on the

---

<sup>25</sup>Refer to <http://www5.cao.go.jp/j-j/wp/wp-je01/wp-je01-2-2-06z.html>.



1996-1997 period of banking crisis.

In contrast with preceding works, we have found that efficient firms in terms of TFP quit while inefficient ones survived, which suggests a malfunctioning of NSM between 1996 and 1997. Besides, this phenomenon is mainly observed for new entrants and contributes substantially to a fall in macro TFP growth after 1996. The result clearly shows that NSM is not working properly.

One feasible explanation for these results might be the poor functioning of the Japanese banking system. In Japan, where an indirect financial system through banking is still dominant, banks are widely involved in the resource allocation process such as establishment, liquidation, and reconstruction of enterprises. The banking system, suffering from non-performing loan problems after the burst of the bubble economy, might be unable to allocate funds to productive enterprises and eventually these firms leave their competitive market. This suggests that models of firm dynamics should involve financial aspects, at least in recession times, in order to reasonably explain the movement of the real economy.

Although this paper has presented new fact-findings on the working of NSM, there still remain several issues that are beyond the scope of this paper. More thorough analysis of the relationship between NSM and financial sectors is needed to examine the role of financial sectors in firm dynamics. In addition, we have not discussed time-series fluctuations of TFP and its implications on NSM. We have neither examined how inter-firm differentiation of TFP occurs nor how TFP affects a firm's organizational dynamics. These issues will be explored in the next stage of our research.

## References

- Aw, B., X. Chen, and M. Roberts (2001). "Firm-level Evidence on Productivity Differentials and Turnover in Taiwanese Manufacturing." *Journal of Development Economics*. **66** (1), 51–86.
- Bae, S. (2002). "An Analysis of Technological Progress and Technical Efficiency of Japanese and Korean Manufacturing Sector, Different Policy Implications." *Paper presented at JEPA International Conference*.
- Baily, M., C. Hulten, and D. Campbell (1992). "Productivity Dynamics in Manufacturing Plants." *Brookings Papers on Economic Activity, Microeconomics*. pp. 187–249.
- Baldwin, J. and P. Gorecki (1991). "Firm Entry and Exit in the Canadian Manufacturing Sector, 1970–1982." *The Canadian Journal of Economics*. May **24** (2), 300–323.

- Bellone, F., P. Musso, and M. Quéré (2003). “Exiting Firms’ Patterns: Evidence from a French Panel Data Set.” *Paper presented at the International Industrial Organization Conference at Boston*. April 4 to 5.
- Cabinet Office (2001). *Economic White Paper*, (in Japanese): Printing Bureau, Ministry of Finance.
- Campbell, J. (1998). “Entry, Exit, Embodied Technology, and Business Cycles.” *Review of Economic Dynamics*. **1** (2), 371–408.
- Caves, D., L. Christensen, and M. Tretheway (1983). “Productivity Performance of U.S. Trunk and Local Service Airlines in the Era of Deregulation.” *Economic Inquiry*. **21**, 312–324.
- , ———, and W. Diewert (1982). “Output, Input and Productivity Using Superlative Index Numbers.” *Economic Journal*. **92**, 73–96.
- Dunne, T., M. Roberts, and L. Samuelson (1988). “Patterns of Firm Entry and Exit in U.S. Manufacturing Industries.” *The Rand Journal of Economics*. Winter **19** (4), 495–515.
- Ericson, R. and A. Pakes (1995). “Markov-perfect industry dynamics: a framework for empirical work.” *Review of Economic Studies*. **62** (1), 53–82.
- Fukao, K., K. Nishimura, Q. Sui, and M. Tomiyama (2003). “Japanese Banks’ Monitoring Activities and Performance of Borrower Firms: 1981–1996.” mimeo, University of Tokyo.
- , T. Inui, H. Kawai, and T. Miyagawa (2002). “Sectoral Productivity and Economic Growth in Japan: 1970-98.” *Paper presented at the NBER Thirteenth Annual East Asian Seminar on Economics*. June 20-22.
- Galor, O. and O. Moav (2002). “Natural Selection and the Origin of Economic Growth.” *Quarterly Journal of Economics*. **117** (4), 1133–1191.
- Good, D., I. Nadiri, L. Roeller, and R. Sickles (1983). “Efficiency and Productivity Growth comparisons of European and U.S/ Air Carriers: A First Look at the Data.” *Journal of Productivity Analysis*. **4**, 115–125.
- Griliches, Z. and H. Regev (1995). “Firm Productivity in Israeli Industry, 1979–1988.” *Journal of Econometrics*. **65** (1), 175–203.
- Hahn, C.-H. (2000). “Entry, Exit and Aggregate Productivity Growth: Micro Evidence on Korean Manufacturing.” Technical Report 45, OECD Economics Department December.
- Haltiwanger, J. (1997). “Measuring and Analyzing Aggregate Fluctuations: The Importance of Building from Microeconomic Evidence.” *Review of the Federal Reserve Bank of St. Louis*. May/June, pp. 55–77.
- Hayashi, F. and E. Prescott (2002). “The 1990s in Japan: A Lost Decade.” *Review of Economic Dynamics*. **5** (1), 261–235.

- Higuchi, Y., T. Nakajima, M. Nakahigashi, and K. Hino (2003). "Time Series Transition of Government Expenditure and Employment in Regional Areas." *Financial Review*. **67**, 120–149. (in Japanese).
- Hopenhayn, H. (1993). "Entry, Exit, and Firm Dynamics in Long Run Equilibrium." *Econometrica*. **60** (5), 1127–50.
- Hoshi, T. and A. Kashyap (1999). "The Japanese Banking Crisis: Where Did It Come From and How Will It End?" *NBER Working Paper*. (7250).
- Jovanovic, B. (1982). "Selection and the Evolution of Industry." *Econometrica*. **50** (3), 649–70.
- and G. MacDonald (1994). "The Life Cycle of a Competitive Industry." *The Journal of Political Economy*. April **102** (2), 322–347.
- Kobayashi, K., Y. Saita, and T. Sekine (2002). "Forbearance Lending: A Case of Japanese Firms." *Research and Statistics Department Working Paper*. (02-2). Bank of Japan.
- Kuroda, M. and K. Nomura (1999). "An Explanation of the Productivity Paradox: TFP Spillover through Capital Accumulation." mimeo.
- Liu, L. (1993). "Entry-exit, Learning, and Productivity Change." *Journal of Development Economics*. **42**, 217–242.
- and J. Tybout (1996). "Productivity Growth in Chile and Colombia: The Role of Entry, Exit, and Learning." in M. Roberts and J. Tybout, eds., *Industrial Evolution in Developing Countries*, World Bank, Oxford University Press, pp. 73–103.
- McGuckin, R. and S. Nguyen (1993). "Post-Reform Industrial Productivity Performance of China: New Evidence from 1985 Industrial Census Data." *Economic Inquiry*. **31** (3), 323–341.
- Nakajima, T., A. Nakamura, E. Nakamura, and M. Nakamura (2003). "Measuring Firm's R&D Effects on Technical Progress: Japan in the 1990s." mimeo, University of British Columbia.
- , M. Kasuya, Y. Saida, and T. Tanemura (2002). "Sectoral TFP Growth and Structural Change in Japan." Technical Report 01-14, IMES Discussion Paper January. (revised version).
- , M. Nakamura, and K. Yoshioka (1998). "A Method for Estimating Scale Economies and Technical Progress: Sources of Total Factor Productivity for Japanese Manufacturing 1964–1988." *Japanese Economic Review*. **49**, 310–334.
- , Y. Maeta, and K. Kiyota (2000). *Is white-collar productivity low in Japan?*, Research Institute of Ministry of International Trade and Industry.
- Nishimura, K. and M. Shirai (2003). "Can Information and Communication Technology Solve Japan's Productivity-slowdown Problem?" *Asian Economic Papers*. **2** (1), 85–136.
- and Y. Kawamoto (2003). "Why Does the Problem Persist?: "Rational Rigidity" and the Plight of Japanese Banks." *The World Economy*. forthcoming.

- Olley, G. and A. Pakes (1996). “The Dynamics of Productivity in the Telecommunications Equipment Industry.” *Econometrica*. **64** (6), 1263–1297.
- Pakes, A. and R. Ericson (1998). “Empirical Implications of Alternative Models of Firm Dynamics.” *Journal of Economic Theory*. **79**, 1–45”.
- Stiglitz, J. and A. Weiss (1981). “Credit Rationing in Markets with Imperfect Information.” *American Economic Review*. **71** (3), 393–410.
- Tybout, J. (1992). “Linking Trade and Productivity: New Research Directions.” *World Bank Economic Review*. **6** (2), 189–211.

## Appendix

### A Supplementary explanation to N2K Panel

As is described in the text, samples in *BSJBSA* are censored at certain points of employment size (50 employees) and capitalization size (30 million yen). Therefore, if a firm decreases the number of employees or capital and goes out of the range of investigation, it disappears from *BSJBSA*, but actually still exists in the market. It reappears when its employment and capital size criteria are satisfied.

Table A1 summarizes entry/exit patterns of *BSJBSA* firms that satisfy the consistency criteria in the previous subsection. The shadowed area (from group 22 to 63) corresponds to a firm’s re-entry behavior patterns. More than 10 % of the all firms take re-entry action every year. The following three reasons might be considered to explain these considerably large numbers. Firstly, a firm might give wrong answers or no response to questionnaires. Secondly, a firm’s employment or capital size would fluctuate around the censoring points of *BSJBSA*. The table, however, might not support this possibility, because the mean values of employment and capital sizes for re-entry firms are far more than censoring points. Thirdly, a firm might repeatedly experience a merger or a separation. Because *BSJBSA* provides no information to identify specific cases for each firm, we have to simply treat re-entry firms as new entrants.

Table A2 and A3 show the basic statistics for the original *BSJBSA* and for the N2K panel respectively. There are no big differences between the two values before and after for value

Table A1: Entry/exit patterns

group_year	The number of firms						Employment size (the mean value)						Capital size (the mean value, million yen)					
	1991	1994	1995	1996	1997	1998	1991	1994	1995	1996	1997	1998	1991	1994	1995	1996	1997	1998
1 1991	2,423						210					381						
2 1991-1994	946	946					205	193				406	403					
3 1991-1994-1995	723	723	723				230	237	226			513	528	541				
4 1991-1994-1995-1996	873	873	873	873			289	276	269	263		650	705	727	737			
5 1991-1994-1995-1996-1997	1,079	1,079	1,079	1,079	1,079		265	258	248	245	251	521	615	619	644	705		
6 1991-1994-1995-1996-1997-1998	14,610	14,610	14,610	14,610	14,610	14,610	494	493	487	483	483	477	1,581	1,638	1,679	1,727	1,756	1,795
7 1994		610							190				211					
8 1994-1995		318	318						194	201			632	640				
9 1994-1995-1996		318	318	318					167	169	166		318	311	351			
10 1994-1995-1996-1997		321	321	321	321				193	192	196	189	511	518	548	579		
11 1994-1995-1996-1997-1998		2,607	2,607	2,607	2,607	2,607			277	277	280	284	280	687	698	729	750	765
12 1995			395								140			238				
13 1995-1996			257	257							177	176			280	284		
14 1995-1996-1997			242	242	242						156	157	163		319	325	352	
15 1995-1996-1997-1998			1,702	1,702	1,702	1,702					204	208	213	213	407	425	434	441
16 1996				259								178				226		
17 1996-1997				172	172							306	303			239	259	
18 1996-1997-1998				856	856	856						185	194	192		356	343	342
19 1997					326								320				304	
20 1997-1998					1,294	1,294							355	348			332	355
21 1998						1,245								194				254
22 1991-1994-1995-1996-1998	405	405	405	405		405	346	349	346	348		344	745	798	805	819		872
23 1991-1994-1995-1997	102	102	102		102		245	226	222			216	343	300	313			385
24 1991-1994-1995-1997-1998	295	295	295		295	295	267	296	301			295	302	464	493	506		538
25 1991-1994-1995-1998	131	131	131			131	391	384	377				368	1,360	1,363	1,367		1,397
26 1991-1994-1996	82	82		82			226	222		214			240	259		253		
27 1991-1994-1996-1997	53	53		53	53		178	175		183	187		661	715		712	710	
28 1991-1994-1996-1997-1998	341	341		341	341	341	286	280		296	292	302	737	786		833	861	887
29 1991-1994-1996-1998	38	38		38		38	273	250		247		240	277	320		362		409
30 1991-1994-1997	31	31			31		230	213			212		101	102			109	
31 1991-1994-1997-1998	114	114			114	114	226	220			243	235	247	259			283	286
32 1991-1994-1998	80	80				80	285	312				300	460	453				518
33 1991-1995	106		106				200		178				151		164			
34 1991-1995-1996	82		82	82			383	399	400				470		611	650		
35 1991-1995-1996-1997	77		77	77	77		238	265	268	259			227		259	259	301	
36 1991-1995-1996-1997-1998	530		530	530	530	530	356	386	390	379	382	1,333		1,933	1,503	1,540	1,630	
37 1991-1995-1996-1998	36		36	36		36	203	254	231			227	692		924	1,206		1,392
38 1991-1995-1997	21		21		21		318	317			312		731		776		786	
39 1991-1995-1997-1998	33		33		33	33	233	207			230	229	420		429		439	440
40 1991-1995-1998	30		30			30	163	181				225	89		116		135	
41 1991-1996	68			68			173			184			184			261		
42 1991-1996-1997	39			39	39		159			165	161		198			219	221	
43 1991-1996-1997-1998	162			162	162	162	323			320	323	321	647			760	774	798
44 1991-1996-1998	25			25		25	292			386			483	598		946		959
45 1991-1997	47				47		202				200		162				173	
46 1991-1997-1998	161				161	161	169				169	166	193				233	243
47 1991-1998	127					127	240					219	248					284
48 1994-1995-1996-1998		115	115	115		115		304	319	341		328		518	552	554		584
49 1994-1995-1997		40	40		40			189	201		192			275	280		295	
50 1994-1995-1997-1998		109	109		109	109		342	339		315	411		178	193		200	210
51 1994-1995-1998		48	48			48		215	220			205		147	146			168
52 1994-1996		35		35				166		141				438		124		
53 1994-1996-1997		31		31	31			153		144	141			2,253		2,277	2,277	
54 1994-1996-1997-1998		143		143	143	143		209		225	224	218		315		332	335	343
55 1994-1996-1998		24		24		24		242		219		235		148		159		182
56 1994-1997		25			25			117			158			113			120	
57 1994-1997-1998		66			66	66		213			199	201		137			154	158
58 1994-1998		58				58		175				176		353				377
59 1995-1996-1998			125	125		125				167	172	174			253	258		262
60 1995-1997			33		33					180		167			118		120	
61 1995-1997-1998			100		100	100				173		212	224		198		224	232
62 1995-1998			68			68				173			168		353			513
63 1996-1998				95		95					186		198			328		353
	1991	1994	1995	1996	1997	1998												
The number of non re-entry firms	20,654	22,405	23,445	23,296	23,209	22,314												
The number of re-entry firms	3,216	2,366	2,486	2,506	2,553	3,459												
The number of total firms	23,870	24,771	25,931	25,802	25,762	25,773												

added, tangible fixed asset, investment, labor compensation, the number of regular workers, working hours, and depreciation rate.<sup>26</sup>

## **B Calculation method of TFP**

In this appendix we present a methodology for TFP measurement and variables definitions for the calculation.

### **B.1 Methodology**

For the both cross-section and time-series comparability of TFP, we applied the methodology utilized in Caves, Christensen and Diewert (1982), Caves, Christensen and Tretheway (1983), and Good, Nadiri, Roeller and Sickles (1983). To avoid complex arithmetical expressions we simply describe the calculation procedure.

1. Define a hypothetical (representative) firm for each year. Its input and output are calculated as geometric means of those of all firms, and its input cost shares as arithmetic means.
2. Calculate TFP index based on the Theil=Törnqvist specification for each firm, for each year, relative to a hypothetical firm calculated in the first step.
3. Make time series of TFP index for a hypothetical firm for each year.
4. Adjust TFP index for each firm of the second step according to a hypothetical firm's TFP index calculated in the previous step.

In the second step, time series (absolute) comparison is impossible because a firm's TFP index has a relative value to a hypothetical firm for each year. A time series linkage of a TFP index for a hypothetical firm in the third step makes it possible to compare a firm's TFP both cross-sectionally and in time series.<sup>27</sup>

---

<sup>26</sup>Careful readers may find the difference in the number of firms between Table A1 and A3. The difference reflects whether the new definition of entry/exit in the previous subsection is applied or not. In Table A4 a re-entry firm is treated as a new entrant. Firms that do not satisfy the consistency conditions, at least for a single year, are entirely excluded from the data set in Table A1 but would be included in Table A3 as a new (re-entry) firm satisfying the consistency conditions.

<sup>27</sup>To illustrate, suppose the TFP index of a hypothetical firm is 1.0 for a benchmark year ( $T$ ) and 1.2 for the next year ( $T + 1$ ). The TFP index numbers at  $T + 1$  for all samples calculated in the second step are adjusted to be

Table A2: Basic statistics for the original *BSJBSA*

	variables	The number of firms	mean	S.D.	min.	10 percentile	median	90 percentile	max.
1991	value added	24,345	12,904	102,933	-36,187	672	2,454	16,093	8,940,898
	tangible asset	24,345	4,311	27,489	0	137	846	5,854	1,481,413
	investment	24,345	1,091	7,805	0	0	82	1,446	419,300
	labor compensation	24,345	1,911	10,264	0	238	580	2,913	578,086
	regular worker	24,345	398	1,649	50	65	146	659	82,221
	working hours	24,351	2,001	108	1,796	1,890	2,000	2,155	2,208
	depreciation rate	24,280	0.16	4.43	0.00	0.02	0.09	0.23	649.00
1994	value added	25,237	7,037	46,094	-18,974	542	1,642	9,636	2,615,367
	tangible asset	25,237	4,593	29,855	0	130	885	6,300	1,327,445
	investment	25,237	583	4,644	-9,332	0	45	770	230,000
	labor compensation	25,237	1,966	10,358	0	238	596	3,085	560,300
	regular worker	25,237	392	1,605	50	64	143	662	77,185
	working hours	25,242	2,005	45	1,822	1,962	1,996	2,066	2,208
	depreciation rate	25,207	0.27	5.84	0.00	0.01	0.06	0.21	589.00
1995	value added	26,424	7,123	44,703	-1,068	555	1,621	9,575	2,331,719
	tangible asset	26,424	4,537	29,229	0	130	873	6,221	1,304,089
	investment	26,424	744	7,317	0	0	46	866	603,384
	labor compensation	26,424	2,064	10,655	2	262	631	3,278	574,947
	regular worker	26,424	381	1,535	50	63	139	653	76,106
	working hours	26,429	2,005	46	1,825	1,967	1,985	2,066	2,173
	depreciation rate	26,388	0.14	2.13	0.00	0.02	0.08	0.21	323.75
1996	value added	26,310	7,712	53,397	-55,958	575	1,674	9,791	3,114,603
	tangible asset	26,310	4,609	28,758	0	129	893	6,377	1,326,891
	investment	26,310	775	6,060	0	0	52	943	439,573
	labor compensation	26,310	2,130	11,097	5	273	652	3,382	654,735
	regular worker	26,310	380	1,520	50	64	141	648	72,837
	working hours	26,315	2,030	49	1,825	1,984	2,015	2,092	2,192
	depreciation rate	26,263	0.12	0.26	0.00	0.02	0.08	0.21	22.05
1997	value added	26,277	7,524	50,046	-25,551	570	1,663	9,598	2,285,374
	tangible asset	26,277	4,706	30,033	0	130	918	6,458	1,366,758
	investment	26,277	798	6,330	0	0	52	965	397,028
	labor compensation	26,277	2,071	11,106	11	265	632	3,224	653,401
	regular worker	26,277	388	1,613	50	63	140	649	75,510
	working hours	26,282	2,015	54	1,818	1,985	1,987	2,093	2,152
	depreciation rate	26,210	0.12	0.85	0.00	0.02	0.08	0.21	83.60
1998	value added	26,270	6,934	44,422	-17,831	543	1,571	9,131	2,417,829
	tangible asset	26,270	4,745	30,034	0	131	930	6,577	1,424,669
	investment	26,270	743	6,228	0	0	41	861	329,523
	labor compensation	26,270	2,024	10,788	9	262	621	3,175	674,022
	regular worker	26,270	385	1,585	50	62	138	645	71,237
	working hours	26,276	1,866	112	1,745	1,745	1,902	2,011	2,096
	depreciation rate	26,219	0.13	1.05	0.00	0.02	0.08	0.22	128.18

Table A3: Basic statistics for the N2K panel

	variables	The number of firms	mean	S.D.	min.	10 percentile	median	90 percentile	max.
1991	value added	23,914	13,074	103,816	1	696	2,489	16,220	8,940,898
	tangible asset	23,914	4,351	27,716	1	142	852	5,886	1,481,413
	investment	23,914	1,102	7,871	0	0	84	1,458	419,300
	labor compensation	23,914	1,924	10,351	0	238	580	2,927	578,086
	regular worker	23,914	400	1,662	50	65	146	662	82,221
	working hours	23,914	2,001	108	1,796	1,890	2,000	2,155	2,208
	depreciation rate	23,914	0.17	4.46	0.00	0.02	0.09	0.23	649.00
1994	value added	24,793	7,085	46,454	4	544	1,648	9,685	2,615,367
	tangible asset	24,793	4,627	30,091	1	135	892	6,330	1,327,445
	investment	24,793	582	4,653	-9,332	0	45	775	230,000
	labor compensation	24,793	1,976	10,441	2	238	597	3,099	560,300
	regular worker	24,793	393	1,615	50	64	143	663	77,185
	working hours	24,793	2,005	45	1,822	1,962	1,996	2,066	2,208
	depreciation rate	24,793	0.27	5.89	0.00	0.01	0.06	0.20	589.00
1995	value added	25,947	7,169	45,049	2	558	1,628	9,601	2,331,719
	tangible asset	25,947	4,570	29,465	1	134	877	6,264	1,304,089
	investment	25,947	748	7,370	0	0	46	867	603,384
	labor compensation	25,947	2,073	10,743	2	261	631	3,276	574,947
	regular worker	25,947	382	1,546	50	63	139	653	76,106
	working hours	25,947	2,005	46	1,825	1,967	1,985	2,066	2,173
	depreciation rate	25,947	0.14	2.15	0.00	0.02	0.08	0.21	323.75
1996	value added	25,818	7,773	53,842	8	578	1,680	9,860	3,114,603
	tangible asset	25,818	4,644	28,998	1	135	898	6,404	1,326,891
	investment	25,818	781	6,108	0	0	52	945	439,573
	labor compensation	25,818	2,137	11,181	5	273	652	3,384	654,735
	regular worker	25,818	381	1,531	50	64	141	648	72,837
	working hours	25,818	2,030	49	1,825	1,984	2,015	2,092	2,192
	depreciation rate	25,818	0.12	0.26	0.00	0.02	0.08	0.21	22.05
1997	value added	25,781	7,599	50,509	2	575	1,667	9,653	2,285,374
	tangible asset	25,781	4,747	30,296	1	137	923	6,490	1,366,758
	investment	25,781	801	6,370	0	0	52	966	397,028
	labor compensation	25,781	2,082	11,203	11	265	633	3,232	653,401
	regular worker	25,781	389	1,625	50	63	141	650	75,510
	working hours	25,781	2,015	54	1,818	1,985	1,987	2,093	2,152
	depreciation rate	25,781	0.12	0.86	0.00	0.02	0.08	0.21	83.60
1998	value added	25,805	6,992	44,801	3	545	1,574	9,142	2,417,829
	tangible asset	25,805	4,781	30,279	1	136	934	6,584	1,424,669
	investment	25,805	748	6,277	0	0	42	860	329,523
	labor compensation	25,805	2,033	10,876	9	262	621	3,183	674,022
	regular worker	25,805	385	1,596	50	62	138	645	71,237
	working hours	25,805	1,867	112	1,745	1,745	1,902	2,011	2,096
	depreciation rate	25,805	0.13	1.05	0.00	0.02	0.08	0.22	128.18



## B.2 Variable definitions for TFP calculation

### *Output*

To describe production technology in general, output is defined in terms of gross value while materials are included in input factors. On the other hand, value added, subtracting the latter from the former, is less preferable because it may cause a systematic bias in TFP indicators.<sup>28</sup> In this paper, however, we use value added instead of gross value for output because of the restriction in data availability of *BSJBSA*. In *BSJBSA*, the only available information concerning material input is “amount of goods purchased,” where no breakdown is given. This limitation is very crucial to the calculation of material input price index. Value added deflators are available in *System of National Accounts* by Cabinet Office of Japan.

### *Input*

We define input factors as labor and capital to keep consistency with our output definition. Labor input is simply calculated by multiplying the number of regular workers by annual per capita working hours.<sup>29</sup> Making time-series of capital stock from *BSJBSA*, on the other hand, is really a tricky job. Because *BSJBSA* has considerable numbers of samples with null investment, a well-known perpetual inventory method is not applicable. Instead the following steps are taken to make capital stock series. First we define the book value of a tangible fixed asset in 1994 (a bench mark year) as a real capital stock of 1994.<sup>30</sup> Capital stock for the next term is then calculated according to the following formula.

$$\tilde{K}_{t+1} = \begin{cases} \tilde{K}_t + (K_{t+1} - K_t)/q_{t+1} & \text{if } K_{t+1} - K_t > 0 \\ \tilde{K}_t + (K_{t+1} - K_t) & \text{if } K_{t+1} - K_t \leq 0 \end{cases} \quad t = 1, \dots, T \quad (\text{A2})$$

where  $\tilde{K}_t$  stands for real capital stock at  $t$ ,  $K_t$  for book values of tangible fixed assets, and  $q_t$  for a investment goods deflator.<sup>31</sup> This formula means that positive increments of book values are assumed as net investments and added to real capital stock of the previous term through

---

multiplied by 1.2.

<sup>28</sup>See McGuckin and Nguyen (1993) for more details about this issue.

<sup>29</sup>The statistics of working hours are available in *Monthly Labor Survey* by Ministry of Health, Labor, and Welfare.

<sup>30</sup>This may cause an underestimate of capital stock for older firms.

<sup>31</sup>The statistics of investment goods deflators is available in *System of National Accounts* by Cabinet Office of Japan.

the deflation process. If book values are decreasing, on the other hand, we simply subtract the amount of reduction from real capital stock of the previous term.<sup>32</sup> Interest rates (10-year-bond yield) and depreciation rates for user cost of capital are from Bank of Japan and KEO Data Base respectively.<sup>33</sup> User cost of capital is defined as follows.

$$P_{Kt} = q_t \left( \frac{1 - \tau_t z}{1 - \tau_t} \right) \left( r_t + \delta - \frac{\dot{q}_t}{q_t} \right), \quad (\text{A3})$$

where  $\tau$  is the corporate tax rate on business income<sup>34</sup> and  $z$  denotes the present value of the depreciation deduction on unit nominal investment.<sup>35</sup>

Table A5: Labor and capital cost shares

Summary statistics					
Labor share					
	<i>N</i>	Mean	S.D.	Minimum	Maximum
1994	24793	0.744837	0.164026	0.006031	0.999935
1995	25947	0.779443	0.147063	0.008931	0.999944
1996	25818	0.785927	0.143513	0.004469	0.999952
1997	25781	0.808969	0.133764	0.017319	0.999946
1998	25805	0.796084	0.139587	0.014316	0.999939
Capital share					
	<i>N</i>	Mean	S.D.	Minimum	Maximum
1994	24793	0.255163	0.164026	0.000065	0.993970
1995	25947	0.220558	0.147063	0.000056	0.991069
1996	25818	0.214073	0.143513	0.000048	0.995531
1997	25781	0.191031	0.133764	0.000055	0.982681
1998	25805	0.203916	0.139587	0.000061	0.985684

Source: N2K Panel Data

Table A5 shows labor and capital cost shares based on the definitions above. Relatively high

<sup>32</sup>A decrease in book values appears in the case of greater depreciation and/or disposal of stock than gross investment. Because of the lack of information on capital stock vintage it is quite difficult to apply other procedures than the one described in the text.

<sup>33</sup>Although capital cost and depreciation rates are certainly different, company by company, according to its managerial condition and production technology, the limitation of data availability forces us to assume that capital cost is common to all firms and a depreciation rate is differentiated only between industries. Financial data, materials, and papers published in the Bank of Japan are now available at Tokiwa Sogo Service Ltd. KEO Data Base (KDB) has been developed at Keio Economic Observatory. We thank Koji Nomura for the provision of information about KDB.

<sup>34</sup>The tax rate are quoted from Cabinet Office (2001).

<sup>35</sup>The variables  $z$  is differentiated only by industry and derived so that the following equations are satisfied:  $z = \sum_{t=1}^T \frac{(1-\delta)^{t-1} \delta}{(1+r)^{t-1}}$  and  $(1-\delta)^T \approx 0.05$ . The second equation means that the end point of depreciation period is defined the time when the accumulated depreciation cost approximately equals to 90% of initial investment.

labor cost shares may reflect *BSJBSA*'s wide coverage of small and medium enterprises.<sup>36</sup>

---

<sup>36</sup>To test this possibility, we have estimated Tobit model that has a capital cost share as a dependent variable and sales, firm age, industry dummy variable, and year as independent variables. As a result the coefficient of sales was positive and statistically significant.